

OPERATOR AND UNIT MAINTENANCE MANUAL
INCLUDING REPAIR PARTS AND
SPECIAL TOOLS LIST
FOR

CARGO PALLET, RIBBON BRIDGE
TRANSPORTER
NSN 5420-01-006-7436

Approved for public release; Distribution is unlimited.

*This manual supersedes TM 5-5420-208-12&P, 8 January 1979, including all changes.

HEADQUARTERS, DEPARTMENT OF THE ARMY
22 MAY 1991

WARNING

To avoid death or serious injury, make certain that winch cable hook is secure on pallet lift pin and that both pallet forward lift pins are secure in transporter hooks when hoisting loads.

To avoid death or serious injury, do not stand near or walk under hoisted loads.

Dry-cleaning solvent, P-D-68D, used to clean parts, is potentially dangerous to personnel and property. Avoid repeated and prolonged skin contact or breathing of vapors. Do not use near open flame or excessive heat. Flash point of solvent is 100 to 138 degrees F (38 to 59 degrees C).

To avoid death, serious injury or damage to equipment, do not attempt to retrieve, launch or transport a loaded pallet without first securely tying down the cargo.

To avoid injury to personnel or damage to equipment, use an assistant for all ground operations.

To avoid injury to personnel or damage to equipment, do not retrieve pallet loaded in excess of 10,000 pounds (4536 kg).

To avoid serious injury to personnel or damage to equipment, align lift cable and hook so that it is centered and perpendicular to center of pallet.

To avoid death or serious injury to personnel, install stakes and side rails to prevent loose cargo, such as sand and gravel, from falling off pallet during transport. Be sure that the pallet rear tie-down pins are secured in transporter tie-down hooks.

To avoid death or serious injury, ensure both parking brake and brake lock are engaged before using hydraulic controls.

a/(b blank)

**OPERATOR AND UNIT MAINTENANCE MANUAL
INCLUDING REPAIR PARTS AND SPECIAL TOOLS LIST
FOR
CARGO PALLET, RIBBON BRIDGE TRANSPORTER
(NSN 5420-01-006-7436)**

Current as of 25 January 1990

REPORTING OF ERRORS AND RECOMMENDING IMPROVEMENTS

You can help improve this manual. If you find any mistakes, or if you know of a way to improve the procedures, please let us know. Mail your letter, DA Form 2028 (Recommended Changes to Publications and Blank Forms) or DA Form 2028-2, located in the back of this manual, directly to Commander, U.S. Army Troop Support Command, ATTN: AMSTR-MCTS, 4300 Goodfellow Blvd., St. Louis, MO, 63120-1798. A reply will be furnished directly to you.

Approved for public release, distribution is unlimited.

TABLE OF CONTENTS

			Paragraph	Page
CHAPTER	1.	INTRODUCTION		
Section	I.	General.....	1-1	1-1
	II.	Equipment Description.....	1-6	1-1
CHAPTER	2.	OPERATING INSTRUCTIONS		
Section	I.	Description and Use of Operator's Controls and Indicators (Not Applicable)	N/A	
	II.	Operator Preventive Maintenance Checks and Services..... (Not Applicable)	N/A	2-1
	III.	Operation Under Usual Conditions	N/A	2-1
	IV.	Operation Under Unusual Conditions		2-12
CHAPTER	3.	OPERATOR/CREW MAINTENANCE INSTRUCTIONS (Not Applicable)		3-1
CHAPTER	4.	UNIT MAINTENANCE INSTRUCTIONS		
Section	I.	Lubrication Instructions	4-1	4-1
	II.	Repair Parts, Special Tools and Equipment	4-3	4-1
	III.	Service Upon Receipt	4-6	4-1
	IV.	Unit Preventive Maintenance Checks and Services	4-8	4-3
	V.	Troubleshooting	N/A	4-4
	VI.	Maintenance Procedures.....	4-9	4-4
	VII.	Preparation for Storage or Shipment.....	4-16	4-8

* This manual supersedes TM 5-5420-208-12&P, 8 January 1979, including all changes.

TABLE OF CONTENTS - continued

		Page
APPENDIX	A. REFERENCES	A-1
	B. MAINTENANCE ALLOCATION CHART.....	B-1
	C. COMPONENTS OF END ITEM (Not Applicable)	C-1
	D. ADDITIONAL AUTHORIZATION LIST (Not Applicable)	D-1
	E. EXPENDABLE/DURABLE SUPPLIES AND MATERIALS LIST	E-1
	F. REPAIR PARTS AND SPECIAL TOOLS LIST	F-1
INDEX	Index-1

List of Illustrations

Figure	Title	Page
1-1.	Cargo Pallet.....	1-2
2-1.	Hydraulic Controls.....	2-1
2-2.	Timber and Ramp Placement for Use With Forklift	2-2
2-3.	Loading Arrangements, General Purpose Pallets of Unequal Height or Weight.....	2-4
2-4.	Pallet Retrieval and Launching (Sheet 1 of 2)	2-6
2-4.	Pallet Retrieval and Launching (Sheet 2 of 2)	2-7
2-5.	Nesting Pallets	2-9
2-6.	Slinging Pallet.....	2-10
4-1.	Axle and Roller, Disassembly for Lubrication	4-2
4-2.	Nest Pin, Removal and Installation	4-4
4-3.	Lift Pin, Removal and Installation.....	4-5
4-4.	Axle and Roller, Removal and Installation.....	4-6
4-5.	Identification, Data and Instruction Plates	4-7
F-1.	Repair Parts.....	F-5

List of Tables

Table	Title	Page
2-1	Load Limits for General Purpose Pallets	2-3
4-1	Unit Preventive Maintenance Checks and Services	4-3

CHAPTER 1

INTRODUCTION

SECTION I. GENERAL

1-1. Scope. This manual is for your use in operating and maintaining the Ribbon Bridge Transporter Cargo Pallets.

1-2. Maintenance Forms and Records. Department of the Army forms and procedures used for Equipment maintenance will be those prescribed by DA Pam 738-750, The Army Maintenance Management System (TAMMS).

1-3. Administrative Storage.

Refer to paragraph 4-16.

1-4. Destruction of Army Materiel to Prevent Enemy Use.

Refer to TM 750-244-3 for instructions covering the destruction of the cargo pallet to prevent enemy use.

1-5. Reporting Equipment Improvement Recommendations (EIR).

If your cargo pallet needs improvement, let us know. Send us an EIR. You, the user, are the only one who can tell us what you don't like about your Equipment. Let us know why you don't like the design or performance. Put it on an SF 368 (Product Quality Deficiency Report). Mail it to Commander, US Army Troop Support Command, AMSTR-QS, 4300 Goodfellow Blvd., St. Louis, MO 63120-1798. We'll send you a reply.

SECTION II. EQUIPMENT DESCRIPTION

1-6. Description.

a. The ribbon bridge transporter cargo pallet is designed to provide the transporter with cargo hauling capabilities, when the transporter is not required for transporting the ribbon bridge. The cargo pallet can be launched and retrieved by the transporter and functions as a dump bed with payloads up to 5 tons (4536 kg) and can support payloads up to 9.25 tons (8391 kg) when loaded in place on the transporter for highway travel. The empty pallets can be nested one on top of another, up to seven, and hauled by the transporter.

b. The pallet is an all-welded platform of aluminum landing mat extrusions across I-beam supports on each side. A rectangular box beam structure across the front of the platform provides the pickup point for retrieval and launching of the pallet by the transporter, securing the pallet to the transporter, and securing the pallets when they are stacked in the nested configuration. An outward projecting pin in each forward corner is provided for use in the retrieval and launching operations. An outward projecting pin in each rear corner and a nose anchor in front are provided to secure the pallet to the transporter and secure pallets in the nested configuration. Two nesting plates are provided to secure pallets in the nested configuration. A lifting eye at each corner is provided to allow sling retrieval, launching and nesting of the pallets. Cargo anchoring is provided via 6 recessed tiedown links in the deck and 24 tiedown hooks around the perimeter of the pallet. Sixteen stake pockets installed on the sides and ends in the deck of the pallet accommodate US Standard 4 x 4 timbers and enable side rails to be installed for retaining loose cargo or bulk materials.

c. The cargo pallet is shown in figure 1-1.

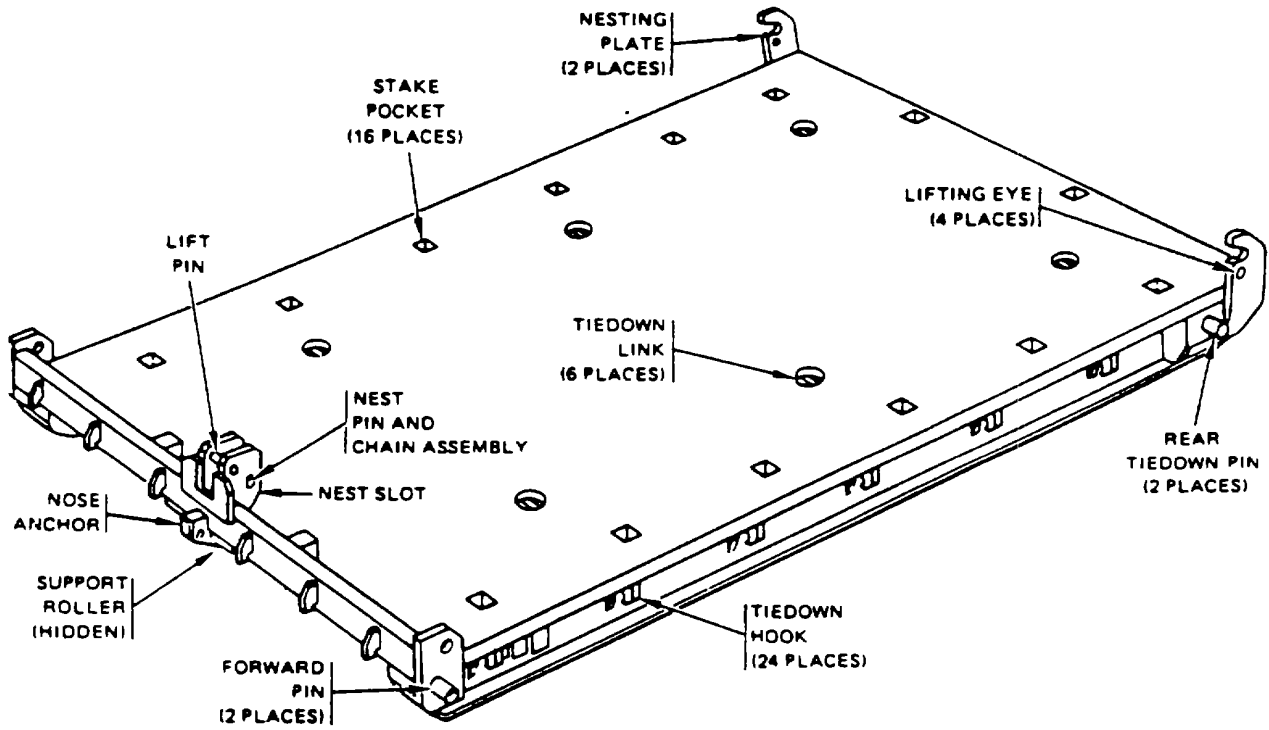

Figure 1-1. Cargo Pallet

1-7. Tabulated Data.

Length	223 in. (566.4 cm)	Six Pallets Nested	Length.....	259 in (658 cm)
Width.....	125 in. (317.6 cm)		Height.....	61 in. (165 cm)
Height.....	19 in. (48 cm)		Weight	8,880 lb (4028 kg)
Weight.....	1,480 lb (671 kg)	Seven Pallets Nested	Length.....	269.5 in. (684.5 cm)
Overall Cargo Area.....	118x220 in. (299.7 x 556.8		Height	69.4 In (176.3 cm)
.....	cm)		Weight	10,360 lb (4699 kg)
Cargo Area Between Stake				
Pickets.....	97x206 in (246.4x523.2			
.....	cm)			
Payload (Including Pallet				
Cross-country	10,000 lb (4536 kg)			
Highway.....	*20,000 lb (9072 kg)			

18,500 pounds (8391 kg) is the maximum net payload of the M812 Transporter when using the Cargo Pallet weighing 1,480 pounds (671 kg).

CHAPTER 2

OPERATING INSTRUCTIONS

SECTION I. DESCRIPTION AND USE OF OPERATOR'S CONTROLS AND INDICATORS
(Not Applicable)SECTION II. OPERATOR PREVENTIVE MAINTENANCE CHECKS AND SERVICES
(Not Applicable)

SECTION III. OPERATION UNDER USUAL CONDITIONS

2-1. General. This section contains instructions for the use of the cargo pallets under normal conditions. It contains procedures for loading/ unloading, cargo tiedown, pallet retrieval and launching, nesting, and load dumping.

2-2. Controls and Instruments. The cargo pallets have no instruments of their own. The operational configurations of the pallets are controlled by the hydraulic console on the transporter. The console is located on the left side behind the cab (figure 2-1).

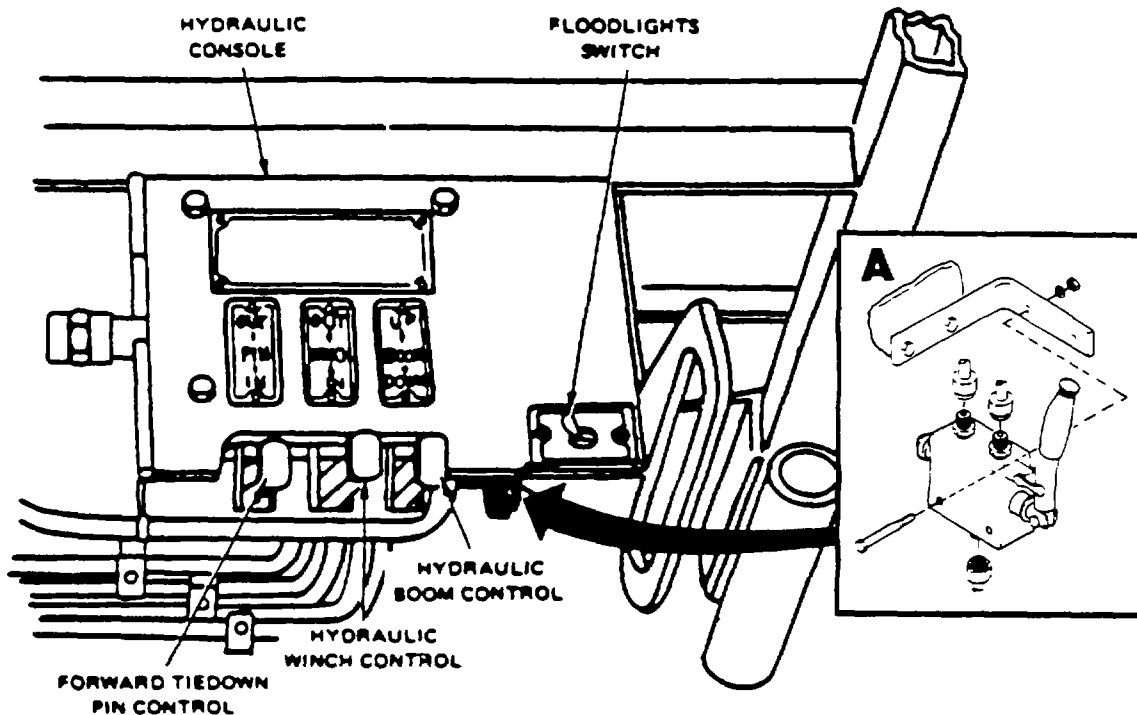

Figure 2-1. Hydraulic Controls

- a. *Forward Tiedown Pin Control.* When the lever is pushed to OUT, the forward tiedown pin is disengaged from the nose anchor of the pallet. When the lever is pulled to IN, it engages the pin in the anchor hole.
- b. *Hydraulic Winch Control.* When the lever is pushed to OUT, it allows the boom cable to pay out slack. When the lever is pulled to IN, the cable is rewind.
- c. *Hydraulic Boom Control.* When the lever is pushed to UP, it raises the boom. When the lever is pulled to DOWN, the boom lowers to the horizontal position on the transporter bed.
- d. *Floodlights Switch.* The toggle switch turns on the floodlights, located on the transporter, to illuminate the work area.

e. *External Throttle Control (Model RBT)*. Mounted on the right side of the transporter hydraulic control console. The throttle control allows the operator to regulate engine speed externally during boom operations.

f. *Selector Valve (Model RBT)*. Mounted on the left side of the transporter cab protector below the hydraulic control console. The valve allows the operator to select either front winch or rear hydraulics.

2-3. Loading/Unloading.

WARNING

To avoid death, serious injury, or damage to equipment, do not attempt to retrieve, launch or transport a loaded pallet without first securely tying down the cargo.

CAUTION

An unbalanced payload or overloaded pallet may hamper retrieval and launching operations.

a. *General*. Cargo weight cannot exceed 10,000 pounds (4536 kg) when the pallet is to be retrieved and/or launched by the transporter, retrieved and/or launched by sling, dumped or transported cross-country. Cargo up to 18,500 pounds (8391 kg) may be loaded for highway transportation when the pallet is secured on the transporter and is not to be launched. Use a forklift truck to position loads and slide into final position as required. For smooth launch and retrieval, it is important to distribute loads as widely and equally as possible. Keep loads centered to maintain pallet balance. If it is necessary to drive the lift truck onto the pallet, 8 x 8 inch (20 x 20 cm) timbers approximately 14 feet (4.27 m) long must first be positioned full length under the pallet, parallel to the sides and a ramp positioned at the rear of the pallet as shown in figure 2-2.

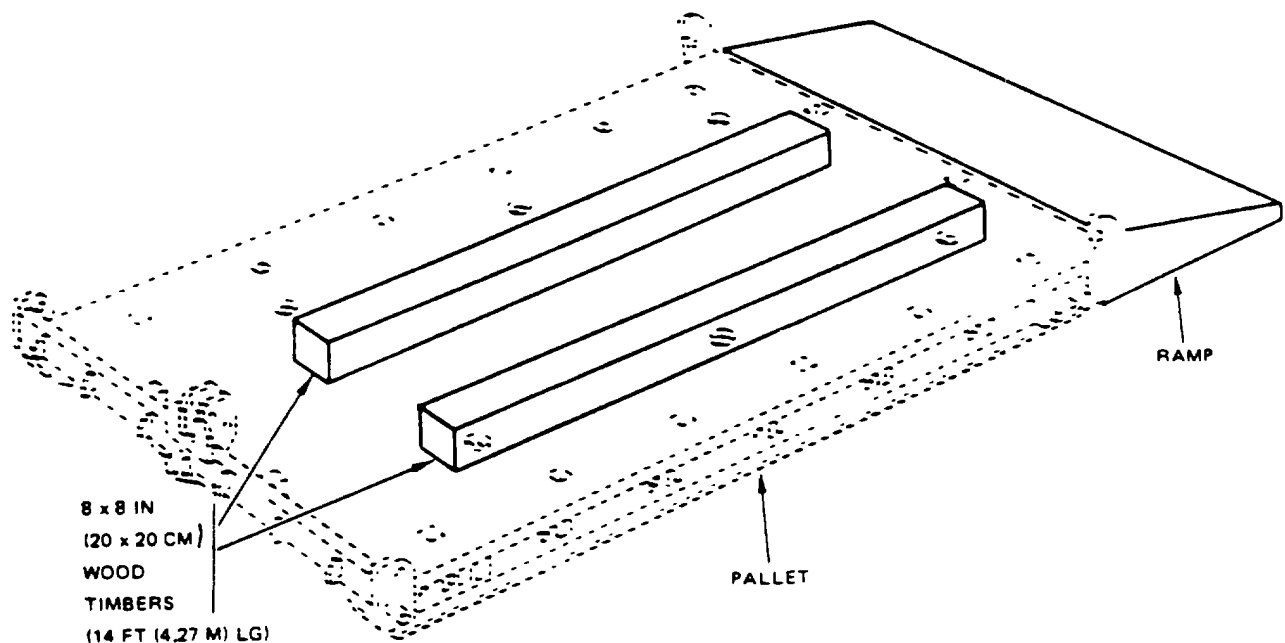

Figure 2-2. Timber and Ramp Placement for Use With Forklift

b. *Procedures*. To avoid damage to the pallet, the following procedures must be adhered to.

(1) General purpose pallets, 40 x 48 inches (102 x 122 cm), loaded with equal weight, which do not exceed the values shown in table 2-1, should be arranged on the cargo pallet in a manner which distributes the total weight over the deck as uniformly as possible, maintaining the balance in the center.

(2) General purpose pallets, 40 x 48 inches (102 x 122 cm), loaded with cargo of unequal height or weight exceeding the values of table 2-1 must be loaded in accordance with figure 2-3.

Table 2-1. Load Limits for General Purpose Pallets

Number of 40 x 48 inch (102 x 122 cm) general purpose Pallets to be loaded	Operation			
	5-Ton (4536 kg) Launch/ Retrieval and Cross Country Max Load/Pallet Pounds(kg)	Total Weight Pounds(kg)	10-Ton (9072 kg) Highway Max Load/Pallet Pounds(kg)	Total Weight Pounds(kg)
1	3500 (1588)	3500 (1588)	4000 (1814)	4000 (1814)
2	3500 (1588)	7000 (3175)	4000 (1814)	8000 (3629)
3	3333 (1512)	9999 (4535)	4000 (1814)	12000 (5443)
4	2500 (1134)	10000 (4536)	4000 (1814)	16000 (7257)
5	2000 (907)	10000 (4536)	3700 (1678)	18500 (8391)
6	1667 (756)	10000 (4536)	3083 (1398)	18500 (8391)
7	1428 (648)	10000 (4536)	2642 (1198)	18500 (8391)
8	1250 (567)	10000 (4536)	2312 (1049)	18500 (8391)
9	1111 (504)	10000 (4536)	2055 (932)	18500 (8391)
10	1000 (454)	10000 (4536)	1850 (839)	18500 (8391)

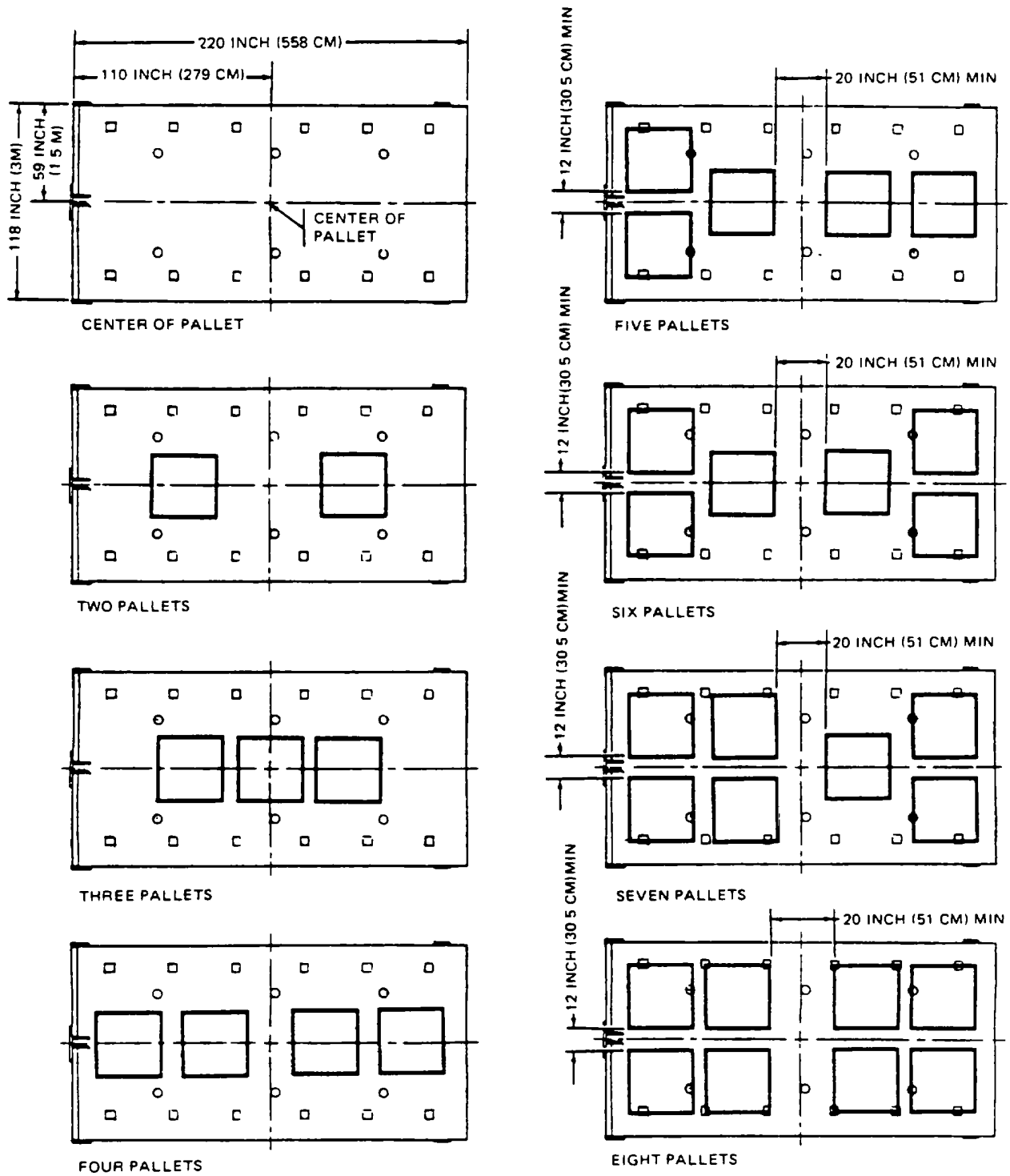

Figure 2-3. Loading Arrangements, General Purpose Pallets of Unequal Height and Weight

(3) Cargo weighing up to the capacity of the cargo pallet which cannot be loaded in accordance with (1) or (2) above can be loaded only after cribbing has been arranged to distribute the load as uniformly as possible over the entire deck area. The balance must be maintained in the center of the pallet.

(4) Racks may be fabricated from standard 4 x 4 inch (10 x 10 cm) timbers with or without planks and installed in the stake pockets to help retain loose cargo and bulk materials such as sand and gravel. If racks are not used while carrying sand or gravel, the stake pockets should be plugged. Plug recessed tiedowns to prevent loss of material. Clean recessed tiedowns and stake pockets after carrying dirt, sand or gravel.

2-4. Cargo Tiedown. The pallet has 24 tiedown hooks around the perimeter of the deck and 6 recessed tiedown links in the deck for use in securing cargo. Stakes or racks may be fabricated and installed in the stake pockets around the perimeter of the deck to help retain loose or bulk cargo. Nets or canvas may be used to secure and protect cargo. Ropes should be run fore, aft, laterally and diagonally over the cargo to securely tie and anchor the cargo to the tiedown hooks and recessed tiedown links. Do not secure tiedown ropes, net or canvas to stakes or racks. The cargo must be secured so that no shifting will occur during retrieval, transport and launching of the pallet. Shifting of cargo during transport may hamper launching of the pallet at its destination. Due to the variety of cargo configurations which may be transported on the pallet, detailed instructions on securing cargo are not given. Good judgment and experience must dictate when the cargo is sufficiently secured

2-5. Pallet Retrieval.

WARNING

To avoid injury to personnel or damage to Equipment, use an assistant for all ground operations.

WARNING

To avoid injury to personnel or damage to Equipment, do not retrieve pallet loaded in excess of 10,000 pounds (4536 kg).

WARNING

To avoid death, serious injury or damage to Equipment, make sure that payload is securely tied down before retrieving pallet.

WARNING

To avoid death or serious injury, engage both parking brake and brake lock before using hydraulic controls.

a. *General.* To retrieve the cargo pallet empty or with cargo up to 10,000 pounds (4536 kg) onto the ribbon bridge transporter, use the rear winch and boom on the transporter.

b. *Procedure.*

(1) Use prybar to retract transporter (tiedown hooks and secure with quick release pins.

(2) Using ground guide, position transporter so that boom pivot is less than 3 feet in front of and aligned with the forward end of the pallet.

(3) With transporter in position, engage parking brake and brake lock, depress and hold clutch pedal, place transmission shift lever in neutral, engage transfer and PTO lever for hydraulic pump. Release clutch pedal.

(4) Set hand or remote throttle to increase engine speed to 1700 rpm.

(5) Remove quick release pin on cylinder locking pin bracket. Use pin-out control lever to disengage pin.

(6) Use winch-out control lever to pay out sufficient amount of cable to allow hook to reach pallet.

(7) Use boom-up and winch-out control levers to raise boom to full vertical position.

(8) Secure winch hook to pallet lift pin.

(9) Use winch-in control lever to play in winch cable and raise pallet enough to clear transporter rear tie down hooks.

(10) Using boom up/down and winch in/out control levers, lower pallet to seat in tiedown hooks (figure 2-4).

(11) Using boom-down and winch-in control levers, play in winch cable and retrieve pallet onto boom ensuring the pallet front roller engages boom guide channel.

(12) Recover pallet fully onto transporter and lower boom.

WARNING

To avoid death or serious injury, make certain that both pallet forward lift pins are secure in transporter hooks.

(13) Align boom sheave with cylinder locking pin bracket and use pin-in control lever to engage pin. Insert quick release pin through bracket.

(14) Using open-end wrench, lock down rear tie down hooks against pallet tie down pins.

(15) Disengage hand or remove throttle, returning engine speed to idle. Depress clutch pedal and raise PTO and transfer case lever to desired range. Disengage parking brake and brake lock, release clutch and continue mission.

2-6. Pallet Launching.

WARNING

To avoid death or serious injury, engage both parking brake and brake lock before using hydraulic controls.

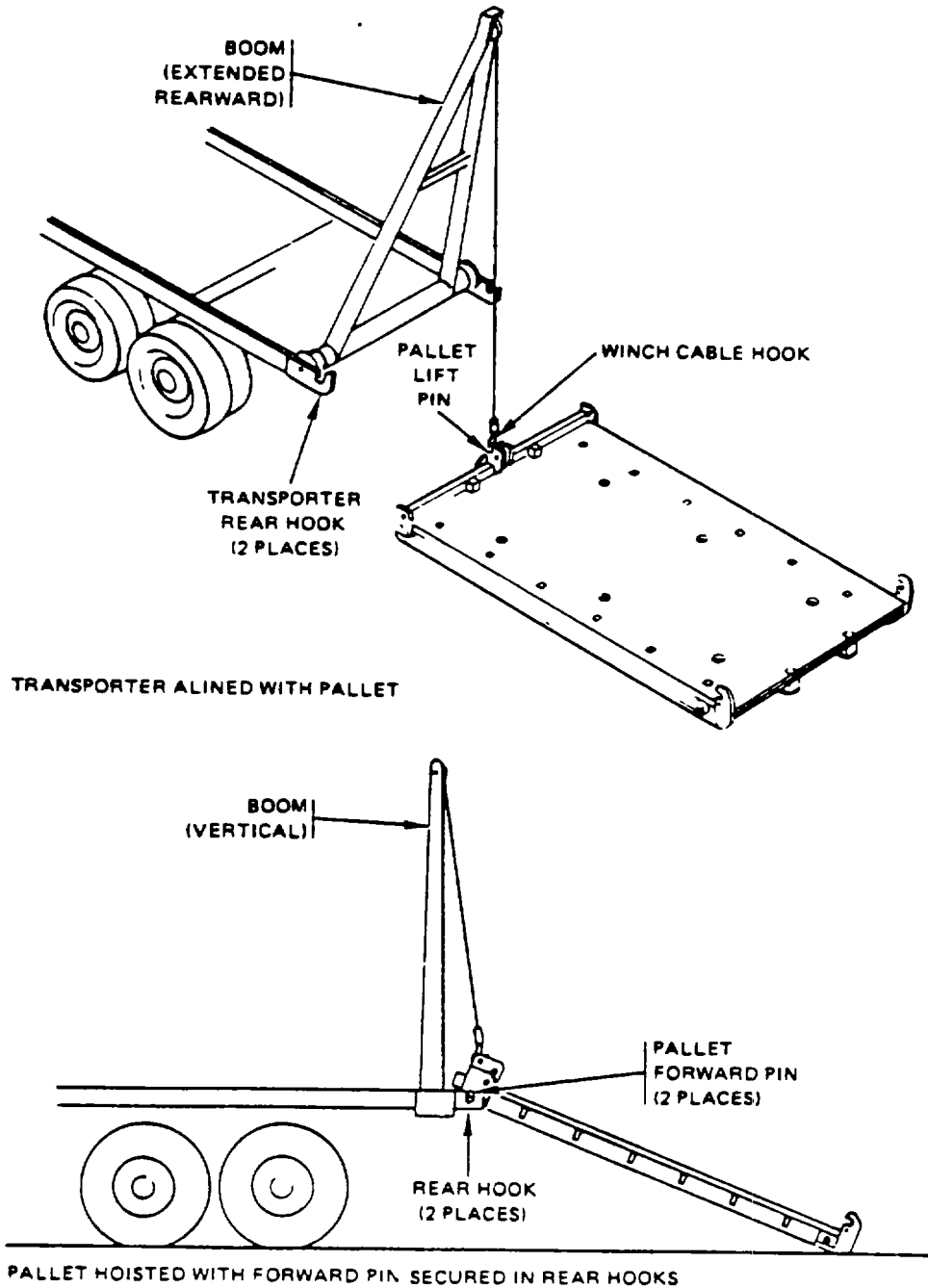

Figure 2-4. Pallet Retrieval and Launching (Sheet 1 of 2)

WARNING

To avoid injury to personnel or damage to equipment, do not launch or retrieve a pallet loaded in excess of 10,000 pounds (4536 kg).

WARNING

To avoid death, serious injury or damage to equipment, do not attempt to launch, retrieve or transport a loaded pallet without first securely tying down the cargo.

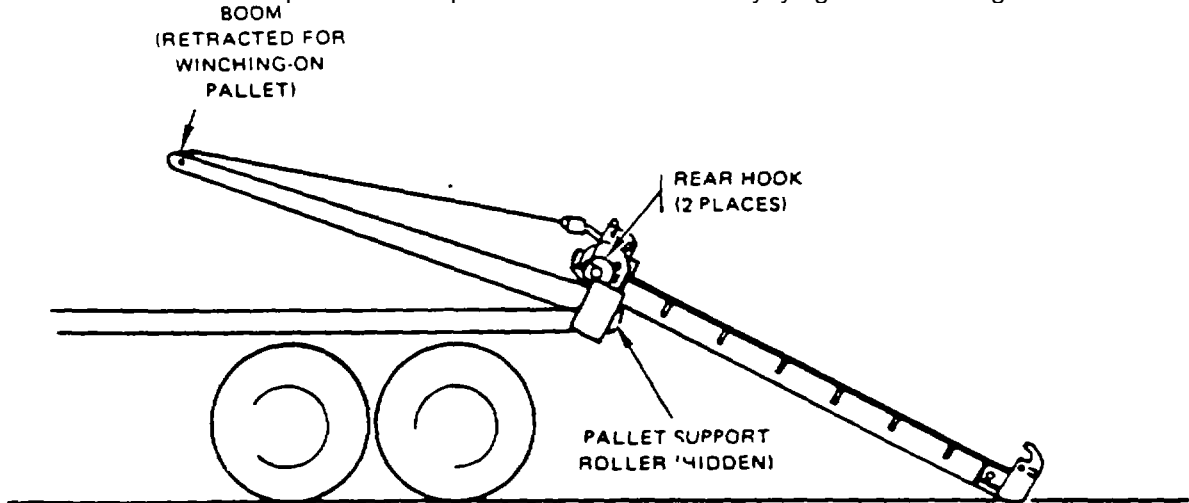

BOOM RETRACTED FOR WINCHING-ON PALLET

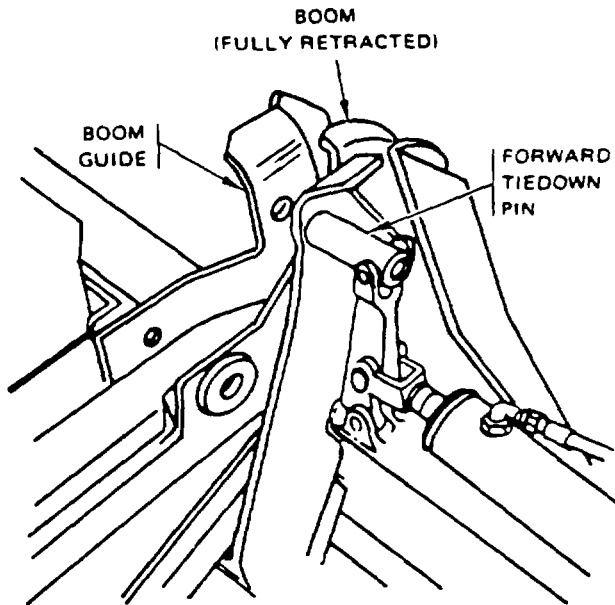

TRANSPORTER LOCKING PIN (PALLET REMOVED FOR CLARITY)

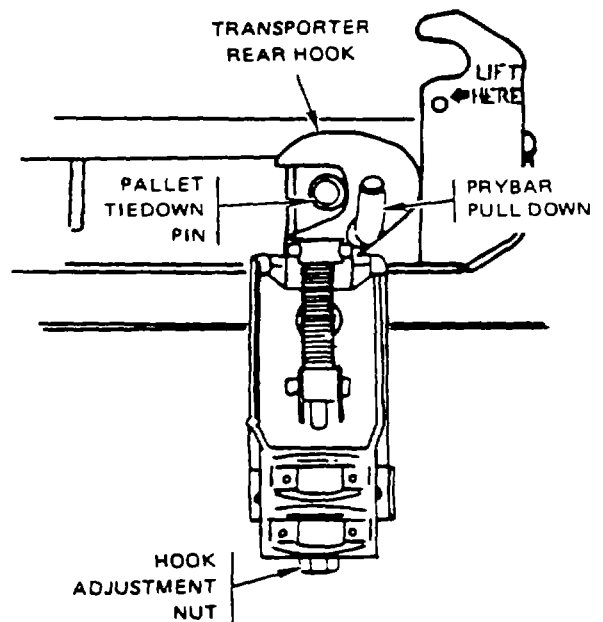

TRANSPORTER REAR HOOK (IN UP POSITION) (2 PLACES)

Figure 2-4. Pallet Retrieval and Launching (Sheet 2 of 2)

WARNING

To avoid death or serious injury, make certain that winch cable hook is secure on pallet lift pin when hoisting loads.

WARNING

To avoid injury to personnel or damage to equipment always use an assistant for all ground operations.

a. *General.* Select a launch site having stable soil with a longitudinal slope of 20% or less.

b. *Procedure.*

- (1) Loosen transporter rear hooks, retract with prybar and secure with quick release pins.
- (2) Remove quick release pin from cylinder locking pin bracket.
- (3) Using ground guide, position transporter for launching the pallet.
- (4) Engage parking brake and brake lock. Depress and hold clutch pedal; place transmission lever in neutral, position transfer case and PTO lever for hydraulic pump and release clutch pedal.
- (5) Set hand or remote throttle to increase engine speed to 1700 rpm.
- (6) Use pin-out control lever to disengage cylinder locking pin.
- (7) Using winch-out and boom-up control levers, pay out winch cable and raise boom enough to allow rear pallet tie down pins to clear transporter tie down hooks.
- (8) Using prybar or equivalent, remove quick release pins and return transporter tie-down hooks to vertical position. Stow pins in receptacles.
- (9) Use boom-up and winch-out controls to pay out winch cable and raise boom until pallet front tie down pins are seated in tie-down hooks. Raise boom to vertical position.
- (10) Using winch-in control lever, raise front of pallet enough to clear tie down hooks.
- (11) Pay out winch cable until pallet rests firmly on ground.
- (12) Pay out additional cable to allow assistant to disconnect hook from pallet lift pin.
- (13) Using winch-in and boom-down control levers, lower boom and rewind winch cable. Secure hook.
- (14) Align boom sheave with locking cylinder bracket; use pin-in control lever to engage cylinder locking pin. Secure quick-release pin through bracket.
- (15) Disengage hand or remote throttle and return engine speed to idle.
- (16) Depress clutch pedal, raise transfer and PTO levers to desired position. Disengage parking brake and brake lock and continue mission.

2-7. Nesting Pallets.

a. *General.* Transporter set-up procedures for nesting pallets is similar to that used in launching, except that empty pallets are stacked (nested) one on top of another, up to seven high (figure 2-5).

b. *Nesting.*

- (1) Remove stakes, racks, and all loose equipment from pallet.

WARNING

To prevent serious injury or equipment damage, always use an assistant for all ground operations.

- (2) Attach guide lines to left front and right rear of pallet.
 - (3) Remove retaining pin and nest pin from nest slot.
 - (4) Load one empty pallet onto the transporter in the same manner as recovering pallet.
 - (5) When the rear of pallet being stacked comes in contact with the pallet below it, use prybar to align pallet tie down pins into nest plates and nose anchor to nest slot.
 - (6) Align nose anchor with nest slot of lower pallet and use winch-out control lever to pay out winch cable nesting the pallet.
 - (7) Insert nest pin and secure with retaining pin.
 - (8) Lock down transporter tie down hooks with open end wrench.
 - (9) Using boom-down and winch-in control levers, lower boom, rewind winch cable and secure hook.
 - (10) Pallets secured to one another in the nested configuration can be shipped or transported
- c. *Retrieving.*
- (1) The procedure for retrieving stacked or individual pallets is identical to the pallet retrieval procedures.
 - (2) Place the cable hook on the pallet lift pin of the top pallet.
 - (3) Remove nest pin securing the pallet being retrieved to the nest lower pallet.
 - (4) Raise top pallet until nose anchor clears nest slot of nest lower pallet while retracting boom, and continue to winch in cable, keeping nose anchor slightly above nest slot until pallet slides forward.

2-8. Pallet Sling Retrieval.

a. *General.* Empty or nested pallets and cargo pallets with a maximum of 10,000 pounds (4536 kg) can be retrieved using a cable sling and a 5-ton crane or equivalent (figure 2-6).

b. *Procedure.*

WARNING

To avoid injury to personnel or damage to equipment, do not launch or retrieve a pallet loaded in excess of 10,000 pounds (4536 kg).

WARNING

To avoid death or serious injury, engage both parking brake and brake lock before using hydraulic controls.

- (1) Using ground guide, position transporter; turn off engine and set parking brake and brake lock.
- (2) Unlock transporter tie down hooks with prybar and insert quick-release pins.
- (3) Remove quick-release pin from cylinder locking pin bracket. Use pin-out control lever to disengage cylinder locking pin.

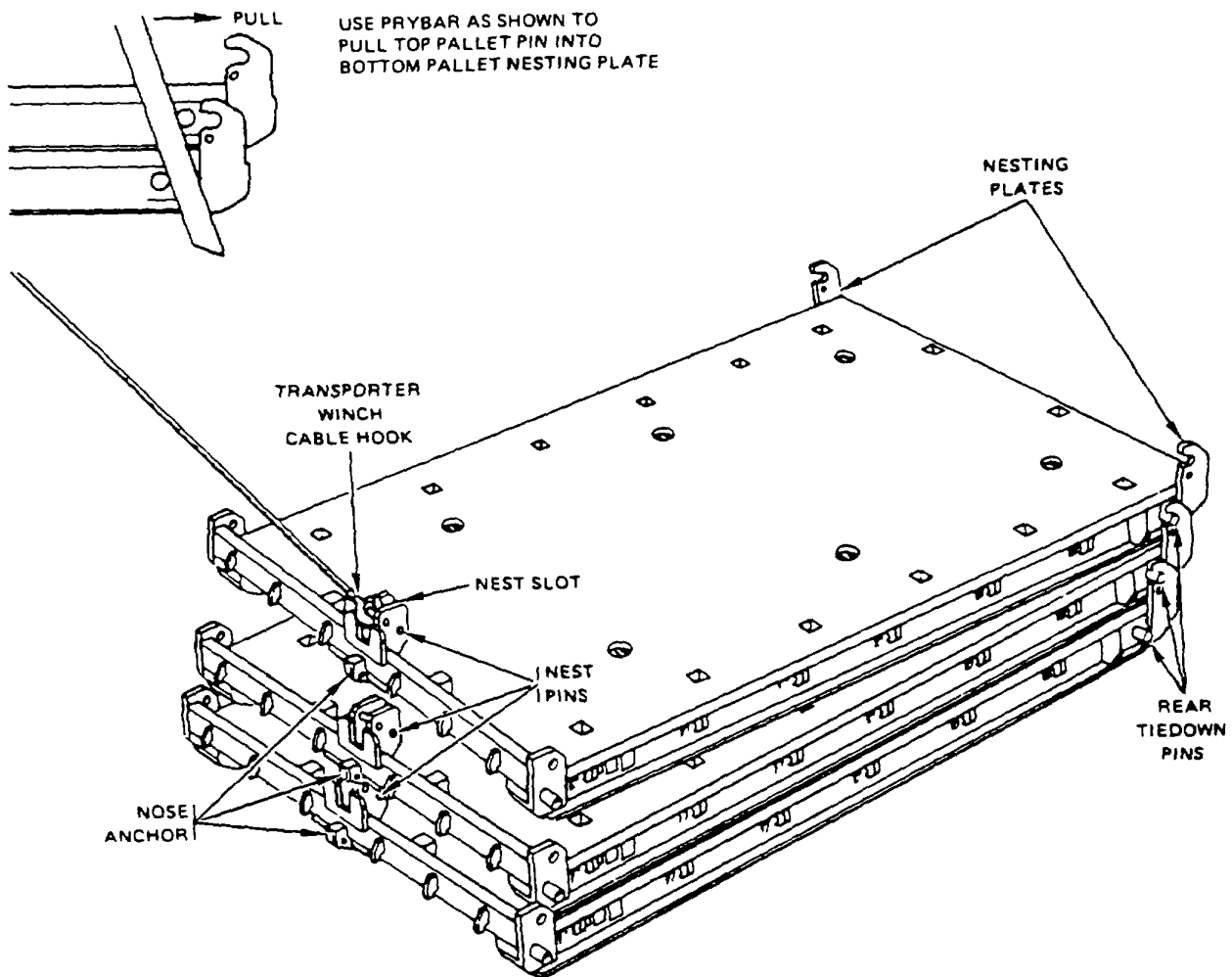

Figure 2-5. Nesting Pallets.

- (4) Position 5-ton crane or equivalent over center of pallet.
- (5) Secure sling to two rear corner lifting eyes of pallet with clevis and pin.
- (6) Place sling hooks through two front corner lifting eyes of pallet.

WARNING

To avoid serious injury or damage to equipment, align lift cable and hook perpendicular with pallet.

- (7) Secure sling lifting eye over lift cable hook; play in cable to take up slack.
- (8) Attach guide lines at front and rear of pallet on crane side of pallet and guide pallet nose anchor into boom guide channel.

WARNING

To avoid death or serious injury, never stand near or cross under hoisted pallet.

- (9) Hoist pallet with a slow, smooth motion and position over transporter.
- (10) Slowly lower pallet onto transporter, ensuring that the rear tiedown pins align with transporter rear hooks and that the nose anchor aligns with transporter boom guide.
- (11) Attach transporter winch cable hook to pallet lift pin.
- (12) Ensure parking brake and brake lock are engaged. Depress and hold clutch pedal, place transmission shift lever in neutral, engage transfer and PTO lever for hydraulic pump and release clutch pedal.
- (13) Set hand or remote throttle to increase engine speed to 1700 rpm.
- (14) Use winch-m control lever to winch in pallet until it seats in boom sheave guide.
- (15) Using pin-in control lever, engage cylinder locking pin and secure bracket quick-release pin.

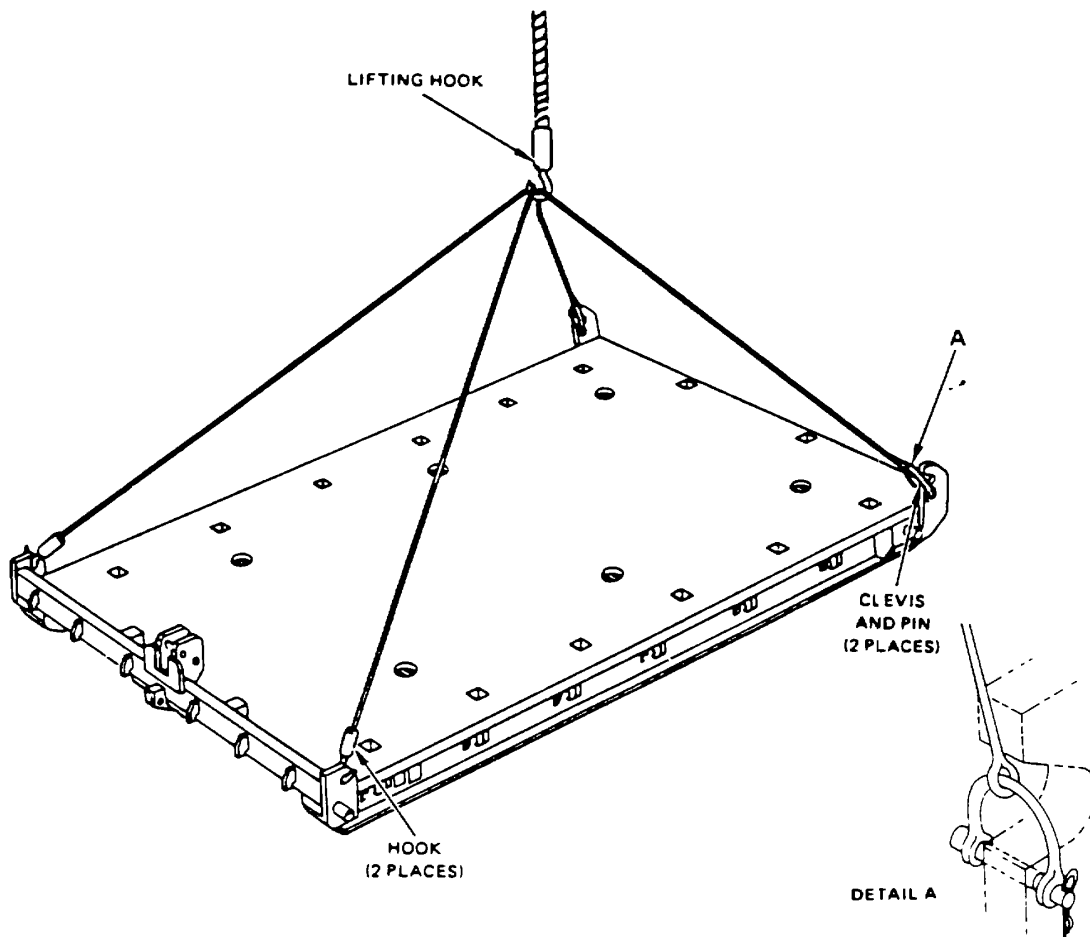

Figure 2-6. Slings Pallet.

NOTE

It may be necessary to raise boom slightly to align pin with anchor hole

- (16) Use prybar to return tie down hooks to vertical position. Insert quick-release pin and lock down hooks with open end wrench.
- (17) Set hand or remote throttle to return engine speed to idle.
- (18) Depress clutch and disengage transfer and PTO, release parking brake and brake lock and continue mission.

2-9. Pallet Sling Launching.

- a. *General.* Empty or nested pallets and cargo pallet, not exceeding 10,000 pounds (4536 kg) can be launched using a 5-ton crane or equivalent and a cable sling (figure 2-6).
- b. *Procedure.*

WARNING

To avoid injury to personnel or damage to equipment, do not launch or retrieve a pallet loaded in excess of 10,000 pounds (4536 kg).

- (1) Position transporter and engage parking brake and brake lock.
- (2) Position 5-ton lifting device over center of pallet.
- (3) Secure sling to two rear corner lifting eyes of pallet with clevis and pin.
- (4) Place sling hooks through two front corner lifting eyes of pallet.
- (5) Secure sling lifting eye over liftline hook and take up slack.

WARNING

To avoid serious injury or damage to equipment, align liftline and hook so it is centered and perpendicular to center of pallet.

- (6) Unlock tie down hooks, retract with prybar and secure with quick-release pins.
- (7) Remove quick-release pin from cylinder locking bracket.
- (8) Use pin-out control lever to retract cylinder locking pin.
- (9) Push the winch control lever to pay out enough cable to remove the cable hook from the pallet lift pin. Secure the hook to the transporter.
- (10) Attach guide lines on crane side of pallet at front and rear of pallet.

WARNING

To avoid death or serious injury, do not stand near or cross under hoisted pallet.

- (11) Hoist pallet from transporter with a slow, smooth motion and lower to ground.

2-10. Pallet Load Dumping.

- a. *General.* The cargo pallet, when secured to the transporter, may be operated as a dump bed to enable rapid discharge of bulk material by using the transporter boom to tilt the load.

WARNING

To avoid death or serious injury, engage both parking brake and brake lock before using hydraulic controls.

CAUTION

Install stakes and side rails to prevent loose cargo, such as sand or gravel, from falling off during transport. Be sure that the pallet rear tie down pins are secured in transporter tie down hooks.

CAUTION

Do not attempt to dump a payload in excess of 10,000 pounds (4536 kg).

- b. *Procedure.*

- (1) Drive loaded transporter to desired location.
- (2) Remove rear rail, if used, from rear stake pockets.
- (3) Make sure winch cable hook is secure on pallet lift pin.
- (4) Remove quick-release pin from cylinder locking bracket.
- (5) Make certain pallet rear tiedown pins are secure under transporter rear hooks.
- (6) Engage parking brake and brake lock, depress and hold clutch pedal, place transmission shift lever in neutral, engage transfer and PTO for hydraulic pump and release clutch.
- (7) Set hand or remote throttle to increase engine speed to 1700 rpm.
- (8) Use pin-out control lever to retract cylinder locking pin.
- (9) Using boom-up control lever, raise boom until pallet and load begins to dump.

- (10) Drive transporter forward, if necessary, until cargo is emptied.
- (11) Using boom-down control lever, lower boom.
- (12) Using winch-in control lever, play in winch cable until pallet nose anchor seats in sheave guide.
- (13) Align nose anchor hole. Using pin control lever, engage locking cylinder pin and secure quick-release pin in bracket.
- (14) Replace rear rail, if used, in rear stake pockets.

SECTION IV. OPERATION UNDER UNUSUAL CONDITIONS

Except for weather, there are no operations under unusual conditions. During wet or cold weather, pallets may become slick and icy. Take appropriate precautions when loading, launching or retrieving pallets under these conditions.

CHAPTER 3

OPERATOR/CREW MAINTENANCE INSTRUCTIONS

There is no operator of this equipment in the usual sense of the word. The driver of the transporter oversees the launching and retrieving of the cargo pallets.

3-1/(3-2 blank)

CHAPTER 4

UNIT MAINTENANCE INSTRUCTIONS

SECTION I. LUBRICATION INSTRUCTIONS

4-1. General. The support roller is the only item on the pallet requiring lubrication.

4-2. Roller Lubrication.

a. Removal (figure 4-1).

- (1) Using a proper sized drift pin, drive the spring pin into axle as far as it will go (figure 4-1, View A).
- (2) Use a brass punch or soft driving pin to drive axle through support plates and roller.
- (3) Remove spring pin, axle and roller.
- (4) Install spring pin in support plate pin hole using a drift pin and hammer. Drive spring pin into hole until flush with support plate (figure 4-1, View B).

b. Cleaning and Lubrication.

WARNING

Dry-cleaning solvent, P-D-680, used to clean parts is potentially dangerous to personnel and property. Avoid repeated and prolonged skin contact. Do not use near open flame or excessive heat. Flash point of solvent is 100 degrees F to 138 degrees F (38 degrees C to 59 degrees C).

- (1) Clean roller and axle with cleaning solvent, item 1, Appendix E Dry with low pressure compressed air.
- (2) Pack roller bearings with grease, item 2, Appendix E.
- (3) Apply grease, item 2, Appendix E, to axle.

c. Installation.

- (1) Position roller between holes in support plates.
- (2) Install axle through holes in support plates and roller, using a soft hammer if necessary.
- (3) Align axle pin hole with pin hole in support plate.
- (4) Install slotted pin in support plate pin hole, using a drift pin to drive slotted pin until flush with support plate (View B).

SECTION II. REPAIR PARTS, SPECIAL TOOLS AND EQUIPMENT

4-3. Repair Parts. Repair parts are listed and illustrated in Appendix F.

4-4. Special Tools and Equipment. No special tools or equipment are required.

4-5. Fabricated Tools and Equipment. No fabricated tools and equipment are required.

SECTION III. SERVICE UPON RECEIPT

4-6. Inspecting and Servicing the Equipment. The cargo pallets shall be given a general inspection for cracks, breaks, broken welds or any other damage. Check to see that the roller is properly lubricated.

4.7. Equipment Conversion. Install 4 x 4 timbers in the stake pockets on the sides and ends in the deck of the pallet and add side rails for retaining loose cargo or bulk materials.

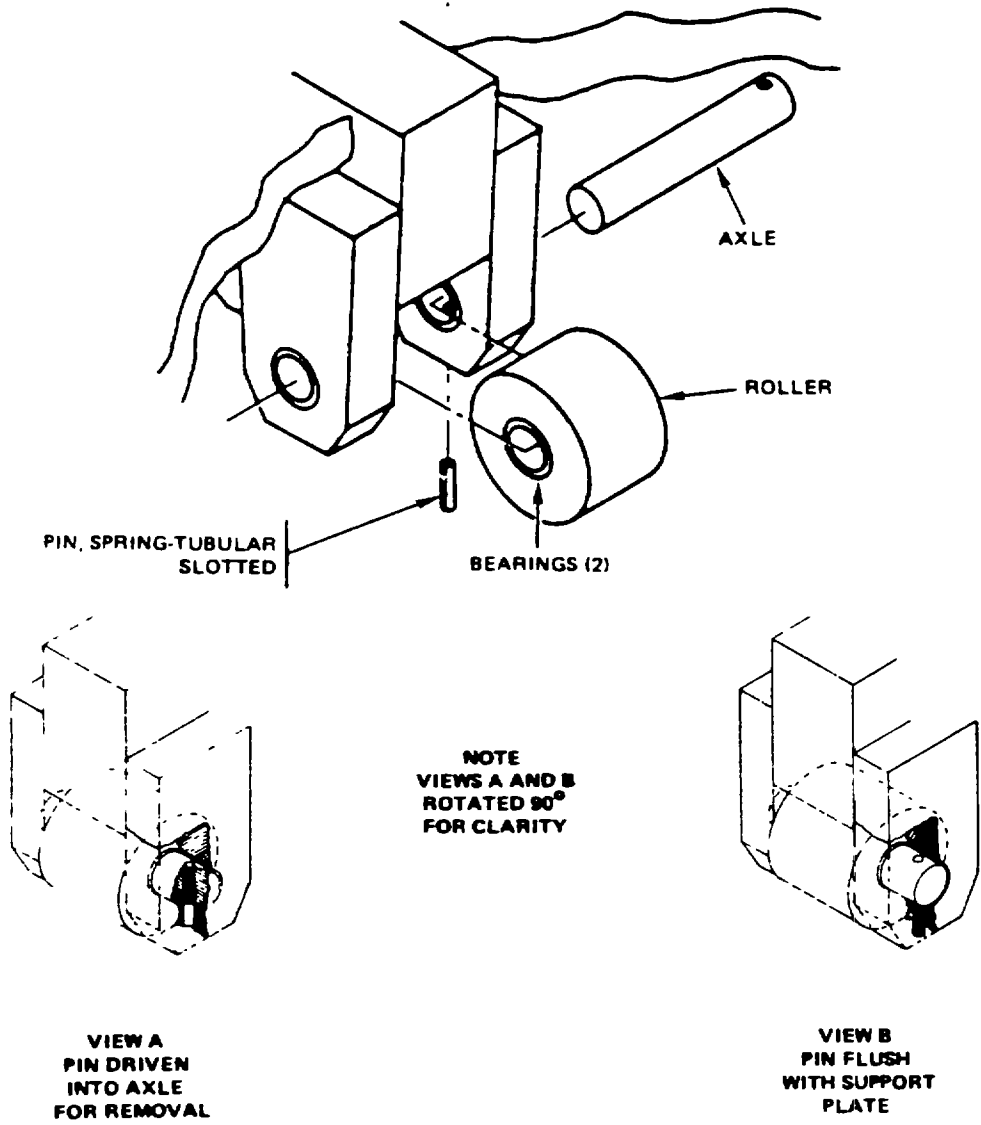

Figure 4-1. Axle and Roller. Disassembly for Lubrication.

SECTION IV. UNIT PREVENTIVE MAINTENANCE CHECKS AND SERVICES

4-8. General. To ensure that the equipment is ready for operation at all times, it must be inspected systematically, so that defects may be discovered and corrected before they result in serious damage or failure.

4-9. Unit Preventive Maintenance Checks and Services (PMCS). Table 4-1 lists and describes preventive maintenance procedures to be performed at the unit level. All deficiencies and shortcomings will be recorded, together with the corrective action taken, on DA Form 2404 (Equipment Inspection and Maintenance Worksheet) at the earliest possible opportunity.

a. Item Number Column. Checks and services are numbered in chronological order. This column is used as a source of item numbers for the TM Number column on DA Form 2404, Equipment inspection and Maintenance Worksheet, in recording results of PMCS.

b. Item To Be Inspected Column. Items listed in this column are divided into groups indicating the portion of the equipment of which they are a part.

c. Procedures Column. This column contains a brief description of the procedure by which the check is to be performed.

d. Not Mission Capable (NMC) Column. This column contains the criteria which will cause the equipment to be classified as not ready/available because of inability to perform its primary mission. These conditions must be corrected to return pallet to mission capable status.

**Table 4-1
UNIT PREVENTIVE MAINTENANCE CHECKS AND SERVICES
Interval - Quarterly**

Item No.	Item to be Inspected	Procedures Check for and have Adjusted/Repaired as Necessary	Not Mission Capable (NMC)
1	Pallet	Check for evidence of pallet or component damage, broken or cracked welds, missing components.	Any evidence of structural or component damage, broken or cracked welds or missing components which will prevent normal operation. Support plate holes worn or elongated, or support plates cracked or broken. One or both plates are cracked or broken. Lift pin is missing.
2	Roller and Axle	Check roller and axle movement. Check roller and axle wear in support plates. Replace defective parts. Lubricate as required.	
3	Nest Pin	Check that nest pin is seated properly and is secured with ring and pins. Ensure that chain attaches nest pin to ring. Replace defective parts.	
4	Nesting Plates	Check for broken, cracked or worn plates.	
5	Lift Pin	Be sure that lift pin is properly installed and is fastened with spring pins. Replace defective parts.	
6	Instruction, ID and Data Plates	Be sure that instruction, identification and data plates are properly fastened, and legible. Replace defective plates.	

SECTION V. TROUBLESHOOTING

Due to the nature of this equipment and the few moving parts, there should be no malfunctions that require troubleshooting procedures.

SECTION VI. MAINTENANCE PROCEDURES

4-10. Instructions for the inspection and maintenance of the cargo pallets are outlined in the following paragraphs.

4-11. Nest Pin and Retaining Pin.*a. Removal*

- (1) Remove screw and washer securing chain to lift plate (figure 4-2).

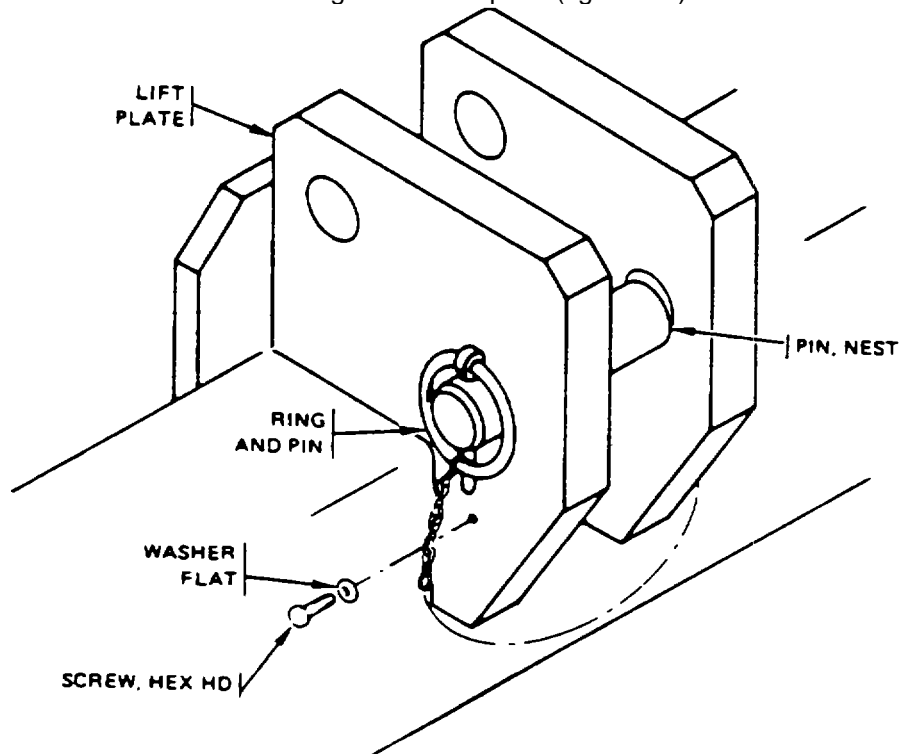

Figure 4-2. Nest Pin, Removal and Installation.

- (2) Lift the ring and remove retaining pin and chain.
- (3) Remove nest pin.

b. Inspection and Repair.

- (1) Inspect nest pin, retaining pin and chain for damage. Ensure free operation.
- (2) Replace damaged or binding pin and chain.
- (3) Replace damaged nest pin.

c. Installation.

- (1) Insert nest pin through holes in nest plate.
- (2) Insert retaining pin and chain and secure by turning ring over end of pin.

4-12. Lift Pin*a. Removal.*

- (1) Use proper sized drift pin to drive one spring pin through lift pin (figure 4-3).
- (2) Remove flat washer and slide lift pin from lift plate.
- (3) Remove remaining washer and slotted pin.

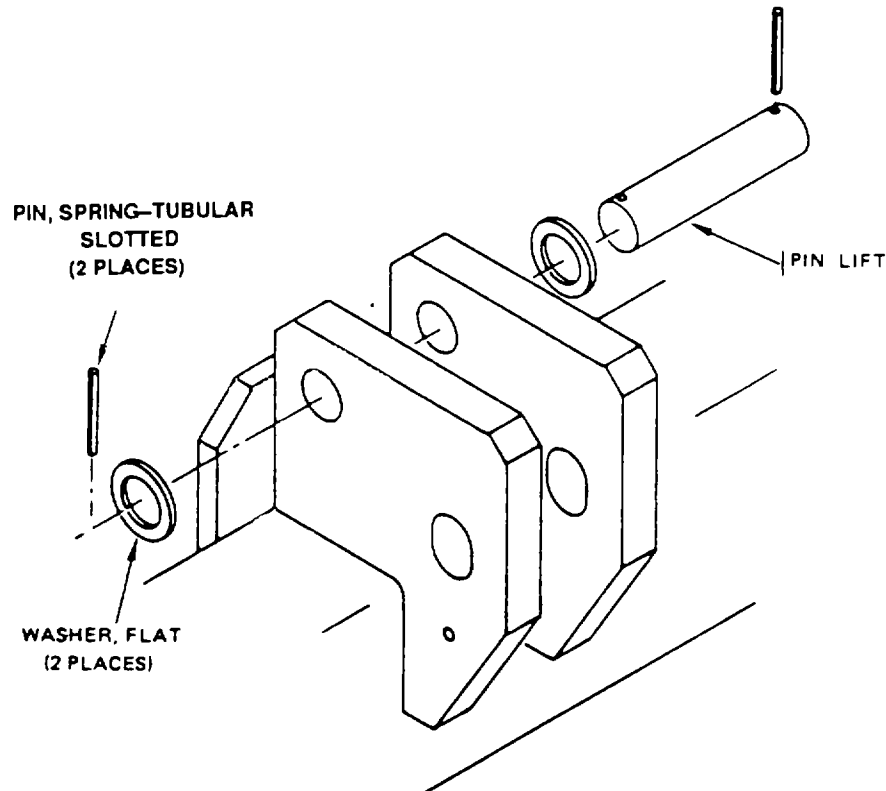

Figure 4-3. Lift Pin, Removal and Installation.

b. Inspection and Repair

- (1) Inspect lift pin for cracks and gouges.
- (2) Repair of lift pin is limited to replacement.

c. Installation.

- (1) Install one spring pin through hole in lift pin using brass punch or soft hammer.
- (2) Place one washer on lift pin.
- (3) Slide lift pin through lift plate holes.
- (4) Install remaining flat washer.
- (5) Install remaining spring pin.

4-13. Axle, Roller and Bearings.

a. Removal.

- (1) Using proper sized drift pin, drive spring pin into axle as far as it will go (figure 4-4).
- (2) Use a soft driving pin and drive the axle out of the support plates and roller.
- (3) Remove roller.
- (4) Use drift pin to drive spring pin

b. Cleaning and Inspection

WARNING

Dry-cleaning solvent, Specification P-D-680, used to clean parts is potentially dangerous to personnel and property. Avoid repeated and prolonged skin contact. Do not use near open flame or excessive heat. Flash point of solvent is 100 degrees F to 138 degrees F (38 degrees C to 59 degrees C).

- (1) Clean roller and axle with cleaning solvent, item 1, Appendix E. Dry with low pressure compressed air.
- (2) Inspect the roller assembly for damage and worn bearings.
- (3) Replace any worn or damaged parts.
- (4) Pack roller bearings with grease, item 2, Appendix E.
- (5) Apply grease, item 2, Appendix E, to axle.

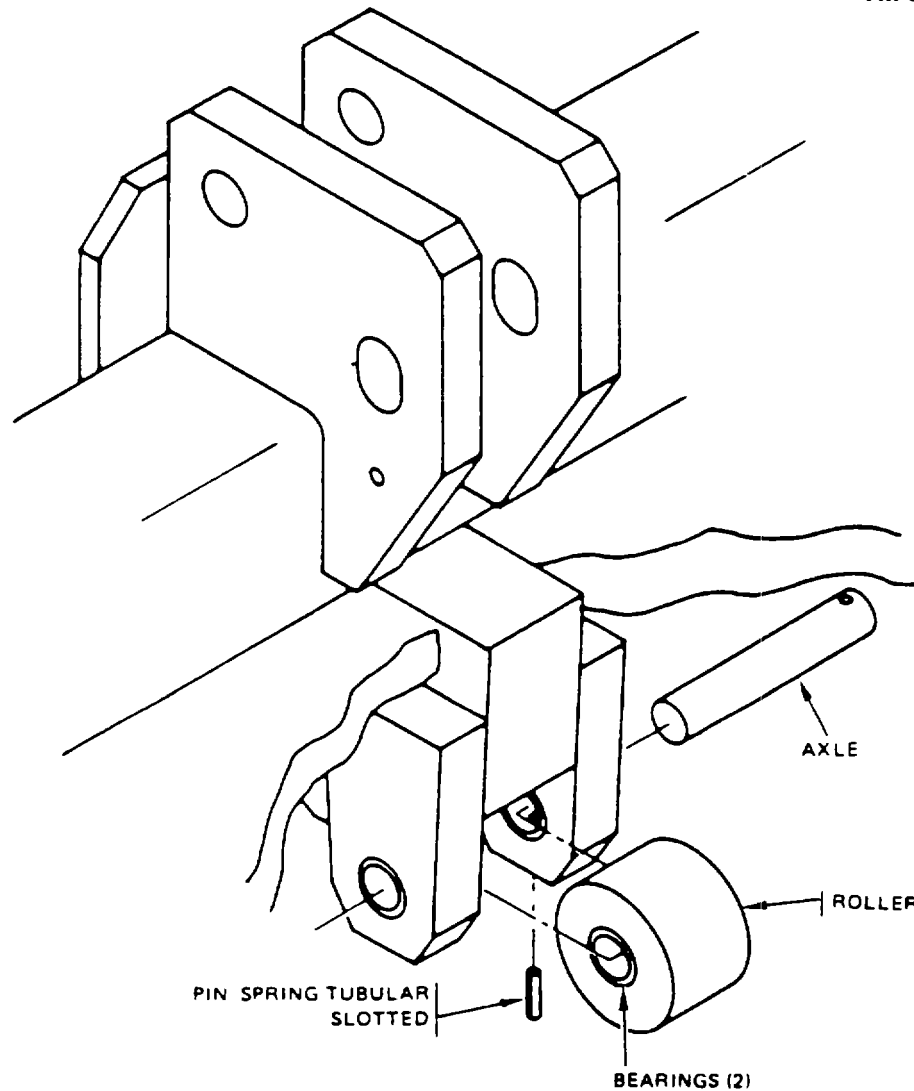

Figure 4-4. Axle and Roller, Removal and Installation.

c. Installation.

- (1) Position roller between holes in support plates.
- (2) Install axle through holes in support plates and roller, using a soft hammer if necessary.
- (3) Align axle pin hole with pin hole in support plate.
- (4) Install spring pin in support plate pin hole. Drive spring pin flush with support plate.

4-14. Identification, Data and Instructions Plates.

a. Removal.

- (1) Use a 1/16-inch drift pin and drive the mandrel from center of rivets (figure 4-5).
- (2) Remove rivets securing plates and remove plates from pallet.

b. Inspection and Repair.

- (1) Check if plates are cracked, worn or illegible.
- (2) Replace any damaged plates.

c. Installation.

- (1) Position plate on cargo pallet and secure in place with four drive rivets.
- (2) Scribe or stamp pallet serial number on new identification plate.

4-15. Pallet Frame and Deck.

a. Inspection. Inspect for cracks, breaks, punctures or tears.

b. Repair. Report damaged pallets to direct support maintenance.

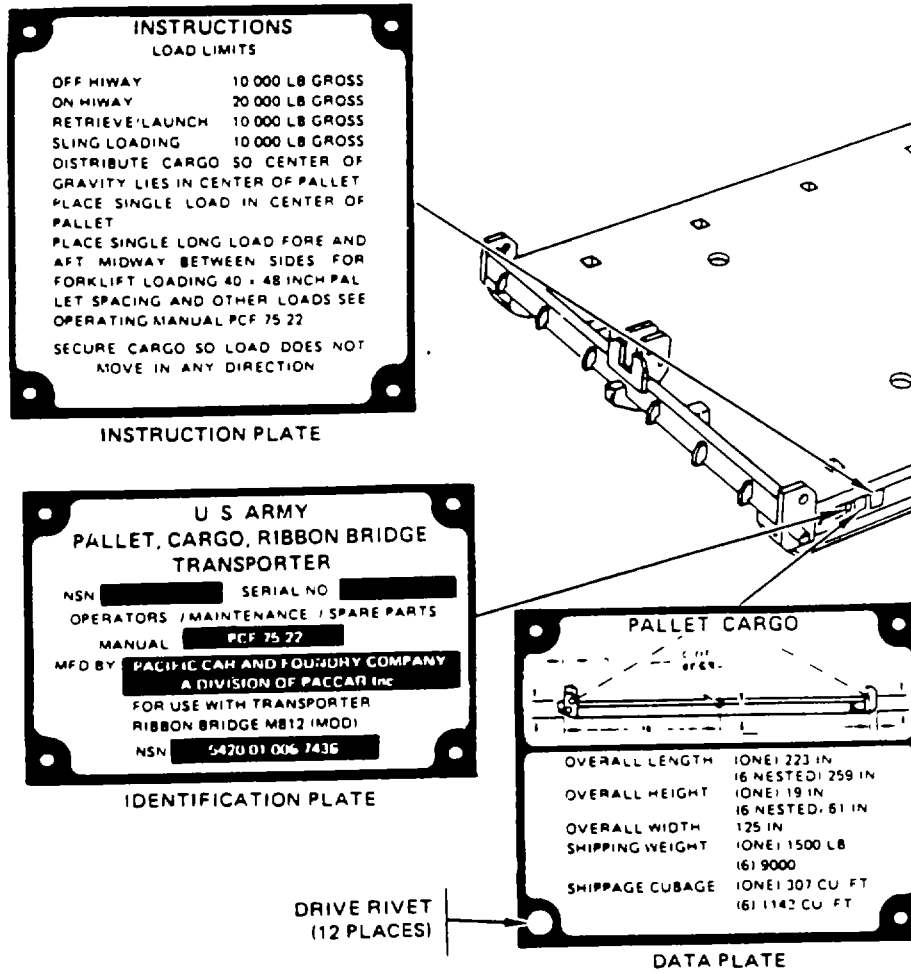

Figure 4-5. Identification, Data and Instruction Plates.

SECTION VII. PREPARATION FOR STORAGE OR SHIPMENT

4-16. Preparation for Storage.

a. Placement of equipment in administrative storage should be for short periods of time when a shortage of maintenance effort exists. Items should be in mission readiness within 24 hours or within the time factors as determined by the directing authority. During the storage period appropriate maintenance records will be kept.

b. Before placing equipment in administrative storage, current maintenance services and equipment serviceable criteria (ESC) evaluations should be completed, shortcomings and deficiencies should be corrected and all modification work orders (MWO's) should be applied.

c. Storage site selection. Inside storage is preferred for items selected for administrative storage. If inside storage is not available, trucks, vans, conex containers and other containers may be used.

4-17. Preparation for Shipment.

Refer to Chapter 1, Operating Instructions.

APPENDIX A

REFERENCES

A-1. Destruction

TM 750-244-3	Procedures for Destruction of Equipment to Prevent Enemy Use
--------------	--

A-2. Maintenance.

TM 43-0139 DA PAM 738-750	Painting Procedures for Army Materiel The Army Maintenance Management System (TAMMS)
------------------------------	---

A-3. Forms.

DA Form 2028	Recommended Changes to Publications and Blank Forms
--------------	---

DA Form 2028-2 SF-368	Recommended Changes to DA Publications Product Quality Deficiency Report
--------------------------	---

A-1/(A-2 blank)

APPENDIX B

MAINTENANCE ALLOCATION CHART

SECTION I. INTRODUCTION

B-1. General.

a. This section provides a general explanation of all maintenance and repair functions authorized at various maintenance levels.

b. The Maintenance Allocation Chart (MAC) in section II designates overall responsibility for the performance of maintenance functions on the identified end item or component. The implementation of the maintenance functions upon the end item or component will be consistent with the assigned maintenance functions.

c. Section III lists the special tools and test equipment required for each maintenance function as referenced from section II.

d. Section IV contains supplemental instructions on explanatory notes for a particular maintenance function.

B-2. Maintenance Functions.

a. *Inspect.* To determine the serviceability of an item by comparing its physical, mechanical and/or electrical characteristics with established standards through examination.

b. *Test.* To verify serviceability and detect incipient failure by measuring the mechanical or electrical characteristics of an item and comparing those characteristics with prescribed standards.

c. *Service.* Operations required periodically to keep an item in proper operating condition, i.e., to clean (decontaminate), to preserve, to drain, to paint, or to replenish fuel, lubricants, hydraulic fluids, or compressed air supplies.

d. *Adjust.* To maintain, within prescribed limits, by bringing into proper or exact position, or by setting the operating characteristics to specified parameters.

e. *Align.* To adjust specified variable elements of an item to bring about optimum or desired performance.

f. *Calibrate.* To determine and cause corrections to be made or to be adjusted on instruments or test measuring and diagnostic equipments used in precision measurement. Consists of comparisons of two instruments, one of which is a certified standard of known accuracy, to detect and adjust any discrepancy in the accuracy of the instrument being compared.

g. *Install.* The act of emplacing, seating, or fixing into position an item, part, or module (component or assembly) in a manner to allow the proper functioning of an equipment or system.

h. *Replace.* The act of substituting a serviceable like type part, subassembly or module (component or assembly) for an unserviceable counterpart.

i. *Repair.* The application of maintenance services or other maintenance actions to restore serviceability to an item by correcting specific damage, fault, malfunction, or failure in a part, subassembly, module (component or assembly), end item or system.

j. *Overhaul.* That maintenance effort (services/actions) necessary to restore an item to a completely serviceable/operational condition as prescribed by maintenance standards (i.e., DMWR) in appropriate technical publications. Overhaul is normally the highest degree of maintenance performed by the Army. Overhaul does not normally return an item to like new condition.

k. *Rebuild.* Consists of those services/actions necessary for the restoration of unserviceable equipment to a like new condition in accordance with original manufacturing standards. Rebuild is the highest degree of materiel maintenance applied to Army equipment. The rebuild operation includes the act of returning to zero those age measurements (hours/miles, etc.) considered in classifying Army equipments/components.

B-3. Column Entries Used in the MAC.

a. *Column 1, Group Number.* Column 1 lists group number, the purpose of which is to identify components, assemblies, subassemblies and modules with the next higher assembly.

b. *Column 2, Component/Assembly.* Column 2 contains the names of components, assemblies, subassemblies and modules for which maintenance is authorized.

c. *Column 3, Maintenance Functions.* Column 3 lists the functions to be performed on the item

listed in column 2. (For detailed explanation of these functions, see paragraph B-2.)

d. *Column 4, Maintenance Level.* Column 4 specifies, by the listing of a work time figure in the appropriate subcolumn(s), the lowest level of maintenance authorized to perform the function listed in Column 3. This figure represents the active time required to perform the maintenance function at the indicated level of maintenance. If the number or complexity of the tasks within the listed maintenance function vary at different maintenance levels, appropriate work time figures will be shown for each level. The number of man-hours specified by the work time figure represents the average time required to restore an item (assembly, subassembly, component, module, end item or system) to a serviceable condition under typical field operating conditions. This time includes preparation time, troubleshooting time and quality assurance/quality control time in addition to the time required to perform the specific tasks identified for the maintenance functions authorized in the allocation chart. The symbol designations for the various maintenance levels are as follows:

C	Operator or crew
O	Unit maintenance.
F	Direct support maintenance.
H	General support maintenance.
D	Depot maintenance.

e. *Column 5, Tools and Equipment* Not applicable.

f. *Column 6, Remarks.* Not applicable.

B-4. Column Entries Used in Tool and Test Equipment Requirements . This section not applicable to this equipment.

B-5. Explanation of Columns in Section IV . This section not applicable to this equipment.

SECTION II. MAINTENANCE ALLOCATION CHART
for
Cargo Pallet, Ribbon Bridge Transporter
NSN 5420-01-006-7436

(1) Group Number	(2) Component/ Assembly	(3) Maintenance Function	(4) Maintenance					(5) Tools and Equipment	(6) Remarks
			C	O	F	H	D		
01	Nesting Pin, Retainer and Plates	Inspect		0.1					
		Replace		0.1					
01	Lift Pin	Inspect		0.1					
		Replace		0.1					
03	Axle and Roller Assembly	Inspect		0.1					
		Service		0.1					
		Replace		0.1					
04	Identification and Instruction Plates	Inspect		0.1					
		Replace		0.1					

* Subcolumns are as follows: C - Operator/Crew; O - Unit;
F - Direct Support; H - General Support; D - Depot

**Indicates WT/MH required

APPENDIX C

**COMPONENTS OF END ITEM AND BASIC
ISSUE ITEMS LISTS**

Not Applicable.

C-1/(C-2 blank)

APPENDIX D

ADDITIONAL AUTHORIZATION LIST

Not Applicable

D-1(D-2 blank)

APPENDIX E

EXPENDABLE/DURABLE SUPPLIES AND MATERIALS LIST

E-1. Scope. This appendix lists expendable/ durable supplies and materials you will need to operate and maintain the ribbon bridge transporter cargo pallet. These items are authorized to you by CTA50-970, Expendable Items (except Medical, Class V, Repair Parts and Heraldic Items).

E-2. Explanation of Columns.

a. *Column 1 - Item Number.* This number is assigned to the entry in the listing and is referenced in the narrative instructions to identify the material (e.g., Use drycleaning solvent, item 1, Appendix E).

b. *Column 2 - Level.* This column identifies the lowest level of maintenance that requires the listed item.
 0 - Organizational

c. *Column 3 - National Stock Number.* This is the national stock number assigned to the item; use it to request or requisition the item.

d. *Column 4 - Description.* Indicates the federal item name and, if required, a description to identify the item. The last line for each item indicates the part number followed by the Commercial and Government Entity (CAGE) code in parenthesis.

e. *Column 5 - Unit of Measure (U/M).* Indicates the measure used in performing the actual maintenance function. This measure is expressed by a two-character alphabetical abbreviation (e.g., ea, in, pr). If the unit of measure differs from the unit of issue, requisition the lowest unit of issue that will satisfy your requirements

Section II. EXPENDABLE/DURABLE SUPPLIES AND MATERIALS LIST

(1) ITEM NO	(2) LEVEL	(3) NATIONAL STOCK NUMBER	(4) DESCRIPTION	(5) U/M
1	O		Drycleaning Solvent, Liquid, P-D-680 (81346):	
		6850-00-281-1985	1 Gallon Can	Ea
		6850-00-264-9038	5 Gallon Pail	Ea
		6850-00-264-9037	55 Gallon. Drum	Ea
2	O		Grease, Automotive and Artillery, GAA, MIL-G-10924 (81349):	
		9150-00-065-0029	2 1/4 Ounce Tube	Ea
		9150-00-935-1017	14 Ounce Cartridge	Ea
		9150-00-190-0904	1 Pound Can	Ea
		9150-00-190-0905	5 Pound Can	Ea
		9150-00-190-0907	35 Pound Pail	Ea

E-1/(E-2 blank)

APPENDIX F

REPAIR PARTS AND SPECIAL TOOLS LIST

SECTION I. INTRODUCTION

F-1. Scope. This appendix lists repair parts required for operations and performance of organizational maintenance of the ribbon bridge transporter cargo pallet.

F-2. General.

a. Section II - Repair Parts List. A list of repair parts authorized for use in the performance of maintenance. The list also includes parts which must be removed for replacement of the authorized parts.

b. Section III - Special Tools List. Not applicable.

c. Section IV - National Stock Number and Part Number Index. Not applicable.

F-3. Explanation of Columns. The following provides an explanation of columns found in the tabular listings:

a. Item number. The number used to identify each item called out on figure F-1.

b. Source, Maintenance, and Recoverability (SMR) Codes.

(1) Source code. Source codes to indicate the manner of acquiring support items for maintenance repair, or overhaul of end items. Source codes are entered in the first and second positions of the Uniform SMR Code format as follows:

<i>Code</i>	<i>Definition</i>
PA	Item procured and stocked for anticipated or known usage.
PB	Item procured and stocked for insurance purpose because essentiality dictates that a minimum quantity be available in the supply system.
PC	Item procured and stocked and which otherwise would be coded PA except that it is deteriorative in nature.
PD	Support item, excluding support equipment, procured for initial issue or outfitting and stocked only for subsequent or additional initial issues or outfittings. Not subject to automatic replenishment.
PE	Support equipment procured and stocked for initial issue or outfitting to specified maintenance repair activities.
PF	Support equipment which will not be stocked but which will be centrally procured on demand.
PG	Item procured and stocked to provide for sustained support for the life of the equipment. It is applied to an item peculiar to the equipment which, because of probable discontinuance or shutdown of production facilities, would prove uneconomical to reproduce at a later time.
KD	An item of a depot overhaul/repair kit and not purchased separately. Depot kit defined as a kit that provides items required at the time of overhaul or repair.
KF	An item of a maintenance kit and not purchased separately. Maintenance kit defined as a kit that provides an item that can be replaced at unit or intermediate levels of maintenance.
KB	Item included in both a depot overhaul/repair kit and a maintenance kit.
MO	Item to be manufactured or fabricated at unit level.
MF	Item to be manufactured or fabricated at the direct support maintenance level.
MH	Item to be manufactured or fabricated at the general support maintenance level.
MD	Item to be manufactured or fabricated at the depot maintenance level.
AO	Item to be assembled at unit level.
AF	Item to be assembled at direct support maintenance level.
AH	Item to be assembled at general support maintenance level.
AD	Item to be assembled at depot maintenance level.
XA	Item is not procured or stocked because the requirements for the item will result in the replacement of the next higher assembly.
XB	Item is not procured or stocked. If not available through salvage, requisition.
XD	A support item that is not stocked. When required, item will be procured through normal supply channels.

NOTE

Cannibalization or salvage may be used as a source of supply for any items source coded above except those coded XA or XD.

(2) Maintenance code. Maintenance codes are assigned to indicate the levels of maintenance authorized to USE and REPAIR support Items. The maintenance codes are entered in the third and fourth positions of the Uniform SMR Code format as follows:

(a) The maintenance code entered in the third position will indicate the lowest maintenance level authorized to remove, replace, and use the support item. The maintenance code entered in the third position will indicate one of the following levels of maintenance.

<i>Code</i>	<i>Application/Explanation</i>
C	Crew or operator maintenance performed within unit maintenance.
O	Support item is removed, replaced, used at the unit level.
Z	Support item is removed, replaced, used by the direct support element of integrated direct support maintenance.
F	Support item is removed, replaced, used at the direct support level.
K	Support item is removed, replaced, used at the general support level.
D	Support items that are removed, replaced, used at depot, mobile depot, specialized repair activity only.

NOTE

Codes Z and F will be considered the same by direct support units.

(b) The maintenance code entered in the fourth position indicates whether the item is to be repaired and identifies the lowest maintenance level with the capability to perform complete repair (i.e., all authorized maintenance functions). This position will contain one of the following maintenance codes

<i>Code</i>	<i>Application/Explanation</i>
O	The lowest maintenance level capable of complete repair of the support item is the unit level.
F	The lowest maintenance level capable of complete repair of the support item is the direct support level.
H	The lowest maintenance level capable of complete repair of the support item is the direct support level.
D	The lowest maintenance level capable of the complete repair of the support item is the depot level
L	Repair restricted to designated specialized repair activity
Z	Nonrepairable. No repair is authorized.
B	No repair is authorized. The item may be reconditioned by adjusting, lubricating, etc., at the user level. No parts or special tools are procured for the maintenance of this item.

(3) Recoverability code. Recoverability codes are assigned to support items to indicate the disposition action on unserviceable items. The recoverability code is entered in the fifth position of the Uniform SMR Code format as follows:

<i>Recoverability Codes</i>	<i>Definition</i>
Z	Nonrepairable item. When unserviceable, condemn and dispose at the level indicated in Position 3.
O	Repairable item. When uneconomically repairable, condemn and dispose at unit level.
F	Repairable item. When uneconomically repairable, condemn and dispose at the direct support level
H	Repairable item. When uneconomically repairable, condemn and dispose at the general support level
D	Repairable item. When beyond lower level repair capability, return to depot. Condemnation and disposal not authorized below depot level.
L	Repairable item. Repair, condemnation, and disposal not authorized below depot specialized repair activity level.
A	Item requires special handling or condemnation procedures because of specific reasons (i.e., precious metal content, high dollar value, critical material or hazardous material). Refer to appropriate manual/directives for specific instructions

c. *National Stock Number.* Indicates the national stock number assigned to the item and will be used for requisitioning purposes.

d. *Part Number.* Indicates the primary number used by the manufacturer which controls the design and characteristics of the item by means of its engineering drawings, specifications standards, and inspection requirements to identify an item or range of the items.

NOTE

When a stock numbered item is requisitioned, the repair part received may have a different part number than the part being replaced.

e. *Commercial and Government Entity (CAGE).* The CAGE is a 5-digit numeric code listed in SB 708-42 which is used to identify the manufacturer, distributor, or Government agency, etc.

f. *Description.* Indicates the Federal item name and, if required, a minimum description to identify the item. Items that are included in kits and sets are listed below the name of the kit or set with the quantity of each item in the kit or set indicated in the quantity incorporated in unit column. When the part to be used differs between serial numbers of the same model, the effective serial numbers are shown as the last line of the description.

g. *Unit of Measure (U/M).* Indicates the standard of the basic quantity of the listed items as used m performing the actual maintenance function. This measure is expressed by two- character alphabetical abbreviation (e.g., ea, m, pr, etc.). When the unit of measure differs from the unit of issue, the lowest unit of issue that will satisfy the required units of measure will be requisitioned.

h. *Quantity Incorporated in Unit.* Indicates the quantity of the item used in the breakout shown on the illustration figure, which is prepared for a functional group, subfunctional group, or an assembly. A V appearing in this column in lieu of a quantity indicates that no specific quantity is applicable, (e.g., shims, spacers, etc.).

Section II. REPAIR PARTS LIST

(1) ITEM NO	(2) SMR CODE	(3) NATIONAL STOCK NUMBER	(4) PART NUMBER	(5) CAGE CODE	(6) DESCRIPTION	(7) U/M	(8) QTY
1	PDOFD	5420-01-006-7436	13221E6586	97403	CARGO PALLET	EA	1
1	PAOZZ	5305-00-267-8973	MS90726-4	96906	SCREW, HEX HEAD	EA	1
2	PAOZZ	5310-00-823-8804	MS27183-9	96906	WASHER, FLAT, CD PLD, GEN PUR	EA	1
3	PAOZZ	5315-01-091-2073	33206	99984	PIN, STRAIGHT, HEADLESS, W/CHAIN & RING (NESTING PIN)	EA	1
4	PAOZZ	5315-00-838-4584	MS16562-66	96906	PIN, SPRING, TUBULAR ¼ X 1 ½ L, CD PLD	EA	2
5	PAOZZ	5315-01-089-8014	13221E6570	97403	PIN, STRAIGHT, HEADLESS	EA	1
6	PAOZZ	5310-01-114-7974	AN960XC1816	81352	WASHER, FLAT, 1 1/8 SIZE, CD PLD	EA	2

SECTION II. REPAIR PARTS LIST (Cont'd)

(1) ITEM NO	(2) SMR CODE	(3) NATIONAL STOCK NUMBER	(4) PART NUMBER	(5) CAGE CODE	(6) DESCRIPTION	(7) U/M	(8) QTY
7	PAOZZ	5315-00-844-3663	MS16562-63	96906	PIN, SPRING, TUBULAR, 1/4 X 7/8 L, CD PLD	EA	1
8	PAOZZ	5315.01-115-2679	13221E6583	97403	AXLE, ROLLER	EA	1
9	PAOZZ	3110-01-091-2851	13221E1019	97403	ROLLER	EA	1
10	PAOZZ		13221E6573	97403	PLATE, IDENTIFI- CATION (PALLET ID)	EA	1
11	PAOZZ	9905-01-084-0436	13221E6584	97403	PLATE, IDENTIFI- CATION (PALLET DATA)	EA	1
12	PAOZZ	9905-01-082-6442	13221E6572	97403	PLATE, IDENTIFI- CATION (PALLET INSTRUCTION)	EA	1
13	PAOZZ	5320-01-292-8512	MS24662-188	96906	RIVET, BLIND	EA	12

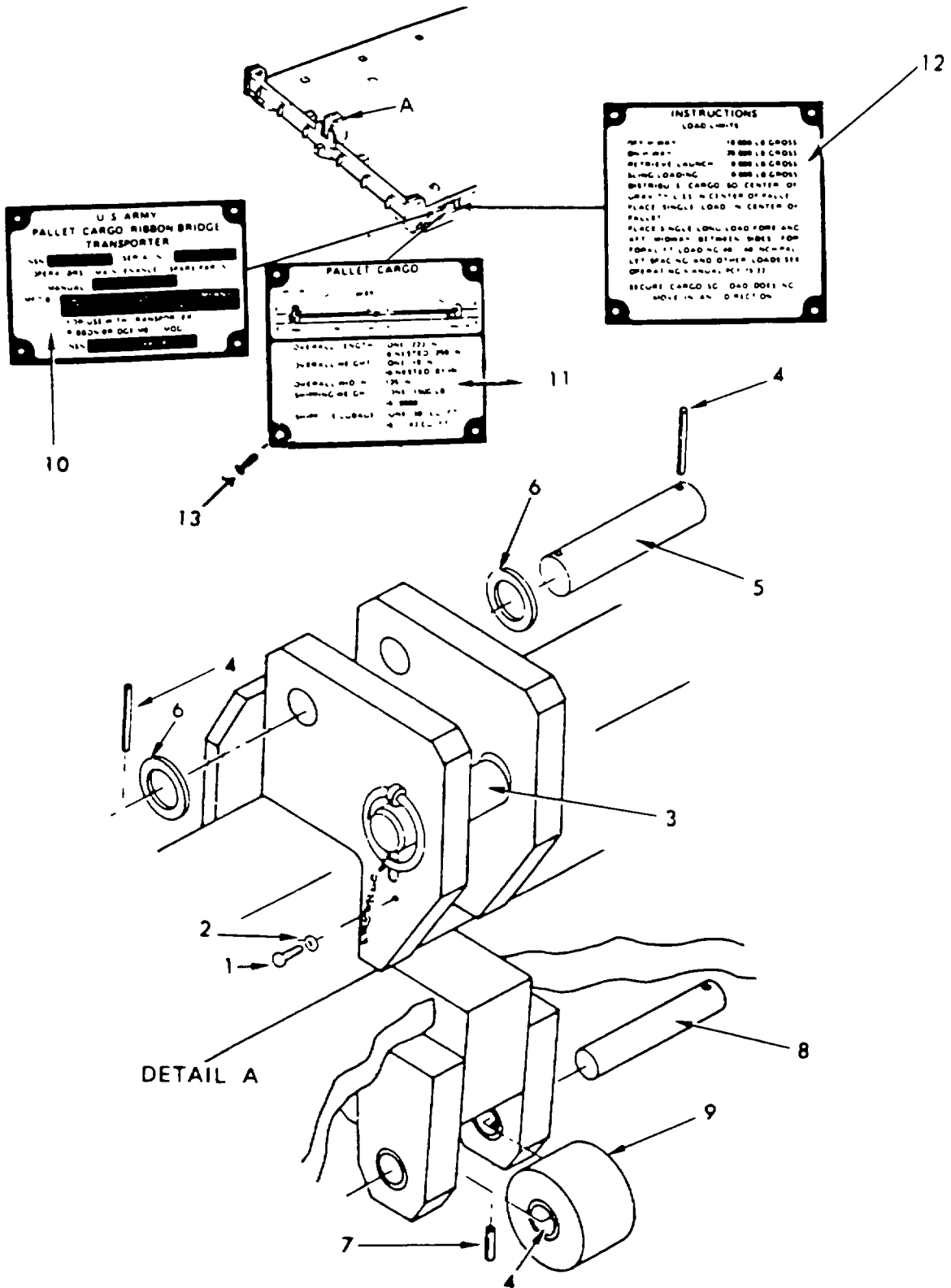

Figure F-1. Repair Parts.

F-5/(F-6 blank)

ALPHABETICAL INDEX

	Paragraph	Page
A		
Administrative Storage	4-15	4-8
Axle, Roller and Bearings	4-13	4-5
Cleaning and Inspection.....	4-13b	4-5
Installation	4-13c	4-6
Removal	4-13a	4-5
C		
Cargo Tiedown	2-4	2-5
Controls and Instruments.....	2-2	2-1
D		
Description	1-6	1-1
Destruction of Army Materiel to Prevent Enemy Use	1-4	1-1
E		
Equipment Conversion	4-7	4-1
F		
Fabricated Tools and Equipment.....	4-5	4-1
I		
Identification, Data and Instruction Plates.....	4-14	4-6
Inspection and Repair.....	4-14b	4-6
Installation	4-14c	4-6
Removal	4-14a	4-6
Inspecting and Servicing Equipment.....	4-6	4-1
Instruments and Controls.....	2-2	2-1
L		
Lift Pin	4-12	4-4
Inspection and Repair	4-12b	4-5
Installation	4-12c	4-5
Removal	4-12a	4-4
Loading/Unloading.....	2-3	2-2
M		
Maintenance Forms and Records.....	1-2	1-1
N		
Nesting Pallets.....	2-7	2-8
Nest Pin and Retaining Pin.....	4-11	4-4
Inspection and Repair.....	4-11b	4-4
Installation	4-11c	4-4
Removal	4-11a	4-4

ALPHABETICAL INDEX (Cont'd)

	Paragraph	Page
P		
Pallet Frame and Deck.....	4-15	4-6
Inspection.....	4-15a	4-6
Repair.....	4-15b	4-6
Pallet Launching.....	2-6	2-6
Pallet Load Dumping.....	2-10	2-11
Pallet Retrieval.....	2-5	2-5
Pallet Sling Launching.....	2-9	2-11
Pallet Sling Retrieval.....	2-8	2-9
R		
Repair Parts.....	4-3	4-1
Reporting Equipment Improvement Recommendations.....	1-5	1-1
Roller Lubrication.....	4-2	4-1
S		
Scope.....	1-1	1-1
Special Tools and Equipment.....	4-4	4-1
T		
Tabulated Data.....	1-7	1-2
U		
Unit Preventive Maintenance Checks and Services.....	4-9	4-3

By Order of the Secretary of the Army:

CARL E. VUONO
General United States Army
Chief of Staff

Official:

PATRICIA P. HICKERSON
Colonel, United States Army
The Adjutant General

DISTRIBUTION:

To be distributed in accordance with DA Form 12-25E, (qty rqr bl no. 0310).

★U.S. GOVERNMENT PRINTING OFFICE: 1991-554-030/40021

RECOMMENDED CHANGES TO EQUIPMENT TECHNICAL PUBLICATIONS



THEN...JOT DOWN THE DOPE ABOUT IT ON THIS FORM. CAREFULLY TEAR IT OUT, FOLD IT AND DROP IT IN THE MAIL.

SOMETHING WRONG WITH PUBLICATION

FROM: (PRINT YOUR UNIT'S COMPLETE ADDRESS)

DATE SENT

PUBLICATION NUMBER

PUBLICATION DATE

PUBLICATION TITLE

BE EXACT PIN-POINT WHERE IT IS

PAGE NO.	PARA-GRAPH	FIGURE NO.	TABLE NO.

IN THIS SPACE, TELL WHAT IS WRONG AND WHAT SHOULD BE DONE ABOUT IT.

TEAR ALONG PERFORATED LINE

PRINTED NAME, GRADE OR TITLE AND TELEPHONE NUMBER

SIGN HERE

The Metric System and Equivalents

Linear Measure

1 centimeter = 10 millimeters = .39 inch
 1 decimeter = 10 centimeters = 3.94 inches
 1 meter = 10 decimeters = 39.37 inches
 1 dekameter = 10 meters = 32.8 feet
 1 hectometer = 10 dekameters = 328.08 feet
 1 kilometer = 10 hectometers = 3,280.8 feet

Weights

1 centigram = 10 milligrams = .15 grain
 1 decigram = 10 centigrams = 1.54 grains
 1 gram = 10 decigrams = .035 ounce
 1 dekagram = 10 grams = .35 ounce
 1 hectogram = 10 dekagrams = 3.52 ounces
 1 kilogram = 10 hectograms = 2.2 pounds
 1 quintal = 100 kilograms = 220.46 pounds
 1 metric ton = 10 quintals = 1.1 short tons

Liquid Measure

1 centiliter = 10 milliliters = .34 fl. ounce
 1 deciliter = 10 centiliters = 3.38 fl. ounces
 1 liter = 10 deciliters = 33.81 fl. ounces
 1 dekaliter = 10 liters = 2.64 gallons
 1 hectoliter = 10 dekaliters = 26.42 gallons
 1 kiloliter = 10 hectoliters = 264.18 gallons

Square Measure

1 sq. centimeter = 100 sq. millimeters = .155 sq. inch
 1 sq. decimeter = 100 sq. centimeters = 15.5 sq. inches
 1 sq. meter (centare) = 100 sq. decimeters = 10.76 sq. feet
 1 sq. dekameter (are) = 100 sq. meters = 1,076.4 sq. feet
 1 sq. hectometer (hectare) = 100 sq. dekameters = 2.47 acres
 1 sq. kilometer = 100 sq. hectometers = .386 sq. mile

Cubic Measure

1 cu. centimeter = 1000 cu. millimeters = .06 cu. inch
 1 cu. decimeter = 1000 cu. centimeters = 61.02 cu. inches
 1 cu. meter = 1000 cu. decimeters = 35.31 cu. feet

Approximate Conversion Factors

To change	To	Multiply by	To change	To	Multiply by
inches	centimeters	2.540	ounce-inches	newton-meters	.007062
feet	meters	.305	centimeters	inches	.394
yards	meters	.914	meters	feet	3.280
miles	kilometers	1.609	meters	yards	1.094
square inches	square centimeters	6.451	kilometers	miles	.621
square feet	square meters	.093	square centimeters	square inches	.155
square yards	square meters	.836	square meters	square feet	10.764
square miles	square kilometers	2.590	square meters	square yards	1.196
acres	square hectometers	.405	square kilometers	square miles	.386
cubic feet	cubic meters	.028	square hectometers	acres	2.471
cubic yards	cubic meters	.765	cubic meters	cubic feet	35.315
fluid ounces	milliliters	29.573	cubic meters	cubic yards	1.308
pints	liters	.473	milliliters	fluid ounces	.034
quarts	liters	.946	liters	pints	2.113
gallons	liters	3.785	liters	quarts	1.057
ounces	grams	28.349	liters	gallons	.264
pounds	kilograms	.454	grams	ounces	.035
short tons	metric tons	.907	kilograms	pounds	2.205
pound-feet	newton-meters	1.356	metric tons	short tons	1.102
pound-inches	newton-meters	.11296			

Temperature (Exact)

°F	Fahrenheit temperature	5/9 (after subtracting 32)	Celsius temperature	°C
----	------------------------	----------------------------	---------------------	----

PIN: 037931-000